

K series eductor mixing nozzles

FUNCTIONS

- Effective, economical way to circulate liquids in closed or open tanks
- No moving parts
- Inherently clog resistant
- Requires minimal maintenance
- Available in both plastic and metal construction

MATERIAL CHARACTERISTIC

Constructed of carbon fiber -glass-reinforced Polypropylene or SS316 Maximum operation temperature 120°C, 300°C for stainless steel. Corrosion resistance and aging resistance.



DESIGN FEATURES

Provide a homogeneous fluid mix without the use of air agitation precluding oxidative decomposition of air agitation of the solutions. Improve circulation of the turbulent flow and optimized mixture of the solutions. Assures uniform mixture of solutions and improve product quality.

PERFORMANCE DATA

Inlet conn. NPT or BSPT(M)	Approx. flow rate	Input hydraulic pressure							
		0.5bar	1bar	1.5bar	2bar	2.5bar	3bar	3.5bar	4bar
1/4	"A"—Inlet flow rate (l/min)	11.3	16	19.5	23	25	28	30	32
3/8		29	42	51	59	65	70	77	82
3/4		43	64	74	85	97	106	116	124
1		54	96	100	107	122	134	146	156
1-1/2		106	151	184	215	243	259	288	308
1/4	"B"—complemental volumn(l/min)	42	59	72	84	93	102	110	118
3/8		116	168	204	236	260	280	308	328
3/4		172	256	298	340	388	424	464	496
1		217	384	390	428	489	534	585	625
1-1/2		424	604	736	860	972	1036	1152	1232
1/4	"A+B"—cicle total flow rate (l/min)	53.3	75	91.5	107	118	130	140	150
3/8		145	210	255	295	325	350	385	410
3/4		215	320	370	425	485	530	580	620
1		271	480	490	536	611	668	731	781
1-1/2		530	755	920	1075	1215	1295	1440	1540
1/4	Effective range(m)	0.91	1.5	2.1	2.6	3	3.7	4.3	5.2
3/8		1.2	1.8	2.4	3.0	3.7	4.3	4.9	6.7
3/4		1.5	2.4	3.4	4.3	5.2	6.1	7.3	10.1
1		2.0	3	4.3	5.4	6.6	7.7	9.2	12.7
1-1/2		2.3	3.7	4.9	6.1	7.3	8.8	10.4	14

Mark :
PP
PPS
PVDF
SS

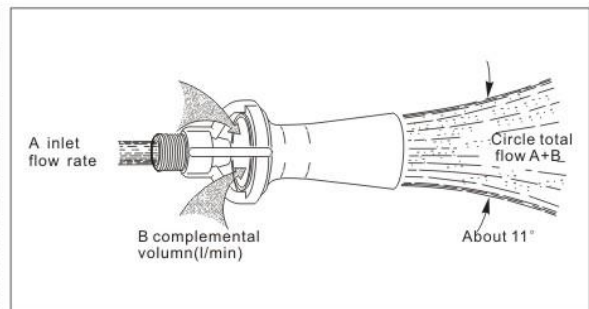

In large solution tank ,annular distribution of the mix fluid nozzle is more effective than mono-distribution, and horizontal arrangement is the lowest efficiency .

The mixing fluid nozzles should be installed at the bottom of the tank in order to get to a maxium circulation rate.

Below are some of the typical distribution of the eductor mixing nozzle.

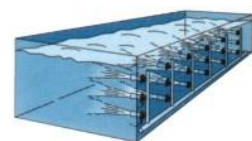
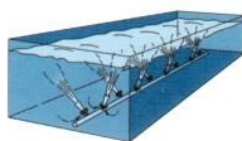
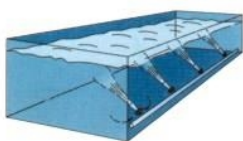

Rectangle or square stirred tank

Stratification stirred tank

Spare parts rinse bath

Gird structured plating bath



K1

DESIGN FEATURES

Use in liquid injection, inhalation, the surrounding liquid, leaves out the amount of liquid is supplied by 3-4 times.
 Simple structure, compact design.
 Standard pressure: 0.5bar.

COMMON APPLICATIONS

- Mixing: liquid mixing, preventing the precipitation, relieving the concentration difference.
- Cleaning: cleaning solution.
- Response: liquid etching, such as electroplating.
- Structure: resin or metal type.
- Material: SS303, PP (A part of injection molding products)

SIZE AND DIMENSIONSS

Nozzle series	Connect thread size	DIMENSIONSS			PP(g)	SS303(g)
		L	Φ d	W		
k1	1/8	30	11	11	1.3*1	11

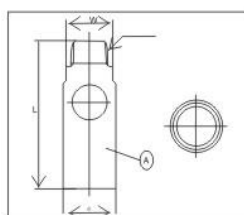

Model No	Inlet conn.(inch)	L(mm)	D(mm)	d(mm)
K2-40	1/4	70	30	23
K2-60	3/8	115	50	38
K2-90	1/2	115	50	38
K2-130	3/4	165	65	50

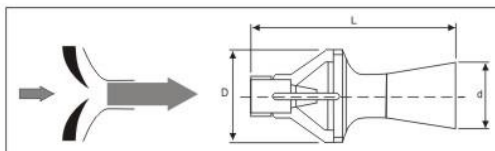

ORDERING INFORMATION

K1 1/8 PP
 ↓ ↓ ↓
 Nozzle type Connect thread size Material code